

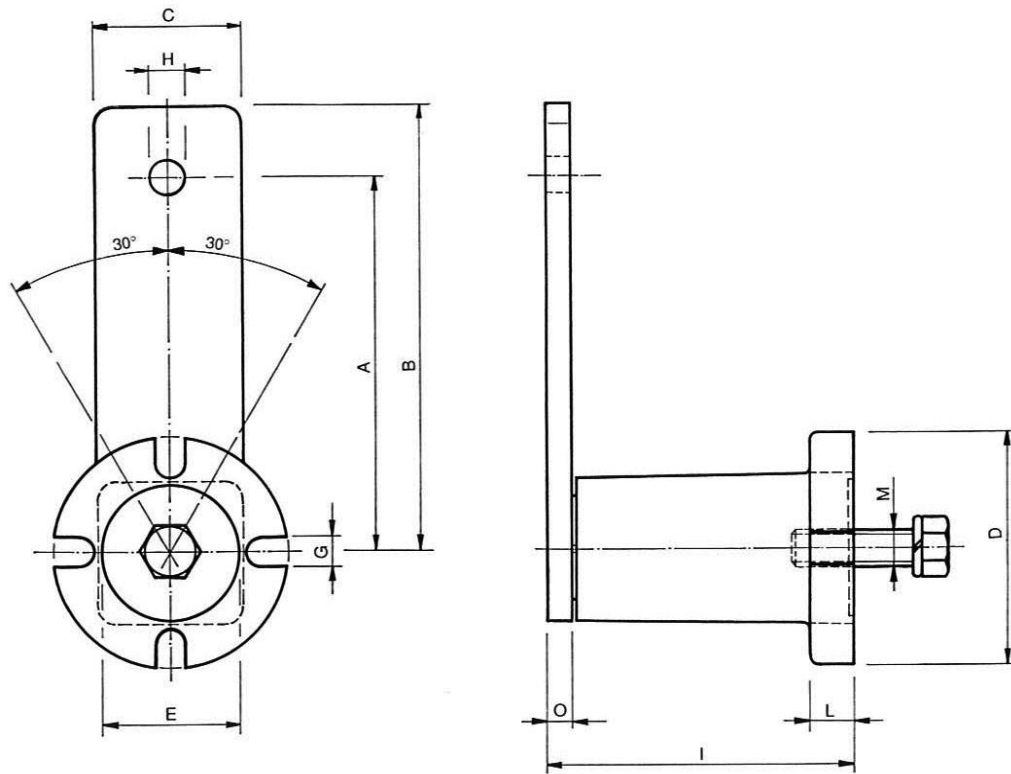

RE.. Elastic Elements (SE..)

Chain and belt tensioner



Type	A	B	C	D (∅)	E (∅)	G	H (∅)	I	L	M	O	T	Newton 0°-30°	Weight
RE10 (SE11)	80	90	25	40	20	7	8,5	50	6	M6	5	25	0-100	0,28
RE20 (SE15)	100	112,5	30	50	30	9	10,5	62	8	M8	5	35	0-150	0,48
RE30 (SE18)	100	115	35	60	35	9	10,5	76	10	M10	6	40	0-340	0,73
RE40 (SE27)	130	155	50	80	48	11	12,5	105	15	M12	8	60	0-850	2,00
RE50 (SE38)	175	205	65	100	62	13	20,5	136	15	M16	10	80	0-1600	4,20
RE60 (SE45)	220	255	80	120	80	13	20,5	196	18	M20	12	115	0-2500	7,00