

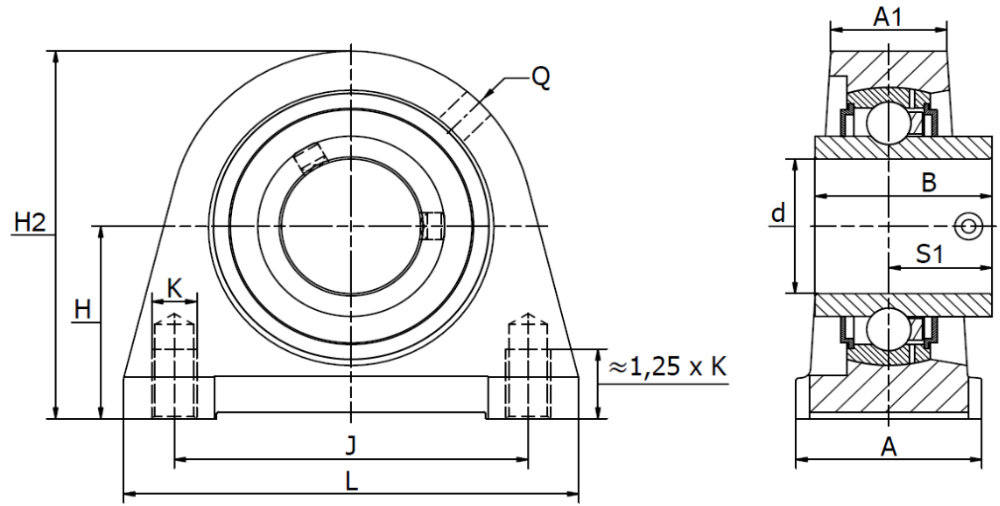

SWG .. U Series (RSHEY)

Cast iron housing, radial insert ball bearing with grub screws in inner ring.
Temperature range -30°C to +110°C



Part No.	d mm	Dimensions (mm)										Bearing No.	Weight (kg)
		L	H ₂	A	A ₁	B	H	J	K	Q	S ₁		
SWG 20 U	20	65	64,0	32	19	31,0	33,3	50,8	M8	M6	18,3	UC 204	0,52
SWG 25 U	25	70	70,0	36	21	34,1	36,5	50,8	M10	Rp 1/8"	19,6	UC 205	0,61
SWG 30 U	30	98	82,0	40	25	38,1	42,9	76,2	M10	Rp 1/8"	22,2	UC 206	1,07
SWG 35 U	35	103	93,0	45	27	42,9	47,6	82,6	M10	Rp 1/8"	25,4	UC 207	1,45
SWG 40 U	40	116	99,0	48	30	49,2	49,2	88,9	M12	Rp 1/8"	30,2	UC 208	1,87
SWG 45 U	45	120	107,0	48	32	49,2	54,0	95,3	M12	Rp 1/8"	30,5	UC 209	2,15
SWG 50 U	50	135	115,0	54	34	51,6	57,2	101,6	M16	Rp 1/8"	32,6	UC 210	2,82
SWG 55 U	55	150	125,0	60	35	55,6	64,0	118,0	M16	Rp 1/8"	33,4	UC 211	3,20
SWG 60 U	60	150	140,0	60	42	65,1	69,9	118,0	M16	Rp 1/8"	39,7	UC 212	4,02