

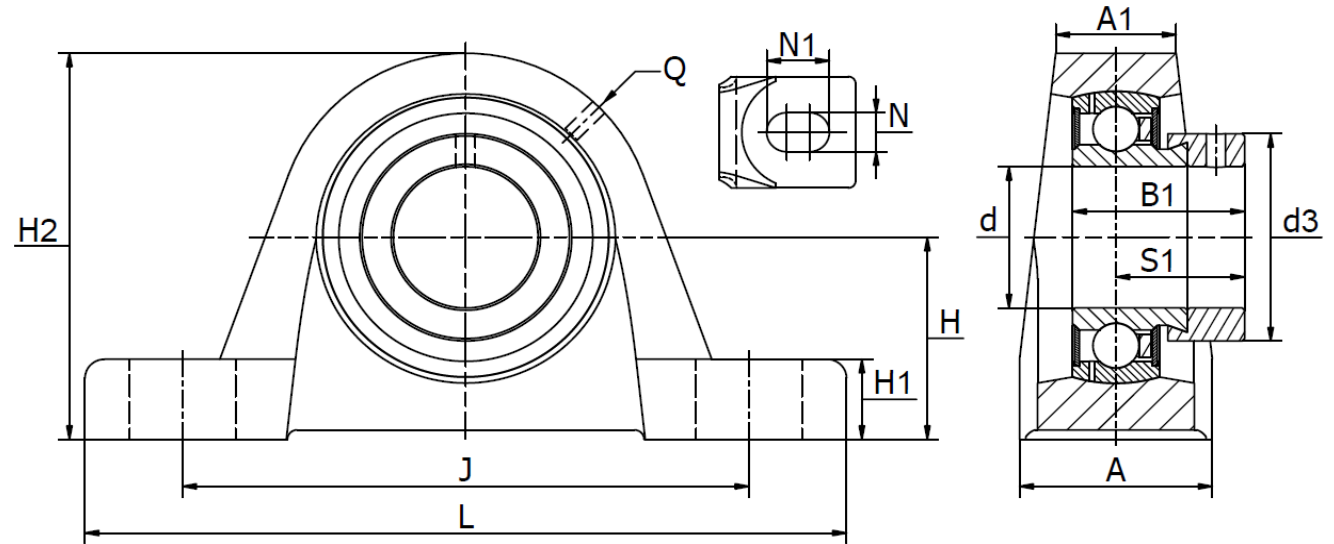

SW.. series (PASE / SY .. FM) - Plummer block housing units

Cast iron housing, radial insert ball bearing with eccentric locking collar. Temperature range -30°C to +110°C



Part No.	d mm	Dimensions (mm)													Bearing No.	Weight (kg)	Cover
		L	H ₂	A	A ₁	B ₁	d _{3 max}	H	H ₁	J	N	N ₁	Q	S ₁			
SW 12-PASE12	12	125	57	30	18	28,6	28	30,2	10	95	11	19	M6	22,1	SA 201	0,46	N/A
SW 15-PASE15	15	125	57	30	18	28,6	28	30,2	10	95	11	19	M6	22,1	SA 202	0,46	N/A
SW 17-PASE17	17	125	57	30	18	28,6	28	30,2	10	95	11	19	M6	22,1	SA 203	0,46	N/A
SW 20-PASE20	20	130	64,0	32	19	31,0	33,0	33,3	14,5	97	11	19	R1/8	23,5	SA 204	0,60	N/A
SW 25-PASE25	25	130	70,0	36	22	31,0	37,5	36,5	14,5	103	11	19	R1/8	23,5	SA 205	0,64	KASK05
SW 30-PASE30	30	158	82,0	40	25	35,7	44,0	42,9	17,0	118	14	22	R1/8	26,7	SA 206	1,04	KASK06
SW 35-PASE35	35	163	93,0	45	27	38,9	51,0	47,6	19,0	126	14	21	R1/8	29,4	SA 207	1,53	N/A
SW 40-PASE40	40	179	99,0	48	30	43,7	58,0	49,2	19,0	138	14	26	R1/8	32,7	SA 208	1,71	KASK08
SW 45-PASE45	45	192	107,0	48	32	42,7	63,0	54,0	21,5	150	14	29	R1/8	32,7	SA 209	2,09	Cover Ø45
SW 50-PASE50	50	200	115,0	54	34	43,7	69,0	57,2	21,5	158	18	23	R1/8	32,7	SA 210	2,47	KASK10
SW 55-PASE55	55	222	124,5	60	35	48,4	76,0	63,5	22,5	176	18	30	R1/8	36,4	SA 211	2,79	N/A
SW 60-PASE60	60	240	140,0	60	42	53,1	84,0	69,9	25,0	190	18	28	R1/8	39,6	SA 212	4,35	KASK12