

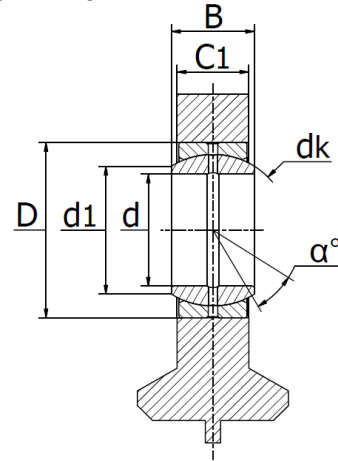

GK..DO - Hydraulic rod ends

with welding face, requiring maintenance, to DIN ISO 12 240

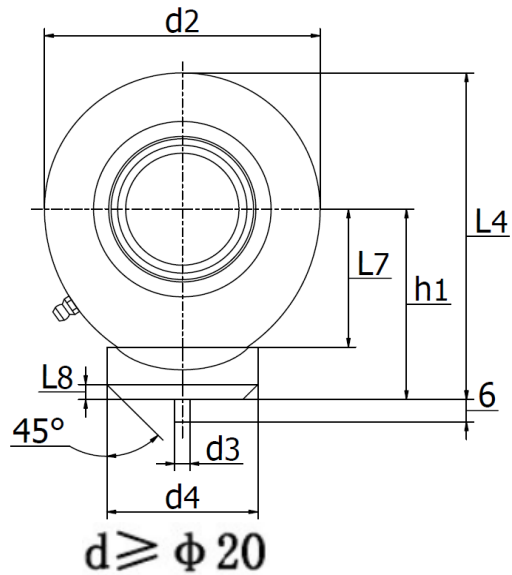
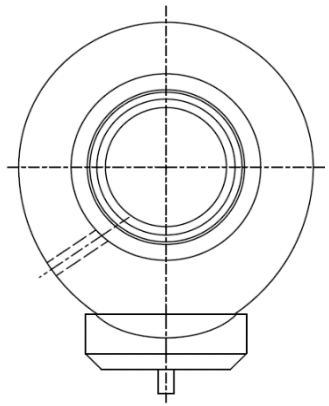

Rod end housing with weldable base and dowel pin.

Made up of a radial spherical plain bearing GE... ES or GE... ES 2RS and rod end housing.

Rod end housing with a lubricating hole or grease nipple.

*Relubrication not possible for the marked sizes.

Material: Steel inner- and outerring.

$\phi 15 \leq d \leq \phi 17$

$d \geq \phi 20$

Part No.	Dimensions (mm)														Load ratings (kN)		Weight (kg)
	d	d ₃	d ₄	B	C ₁	d ₂	L _{7 min}	L ₈	h ₁	L ₄	d _k	d ₁	D	α	dyn. C	stat. C ₀	
GK10DO*	10	3	15	9	7	29	15	1,5	24	38,5	16	13,2	19	12°	8,15	15,6	0,041
GK12DO*	12	3	17,5	10	8	34	18	1,5	27	44	18	15	22	11°	10,8	21,6	0,066
GK15DO	15	4	21	12	10	40	20	2	31	51	22	18,4	26	8°	17	32	0,12
GK17DO	17	4	24	14	11	46	23	2	35	58	25	20,7	30	10°	21,2	40	0,19
GK20DO	20	4	27,5	16	13	53	27,5	2	38	64,5	29	24,2	35	9°	30	54	0,23
GK25DO	25	4	33,5	20	17	64	33	3	45	77	35,5	29,3	42	7°	48	72	0,43
GK30DO	30	4	40	22	19	73	37,5	3	51	87,5	40,7	34,2	47	6°	62	95	0,64
GK35DO	35	4	47	25	21	82	43	3	61	102	47	39,8	55	6°	80	125	0,96
GK40DO	40	4	52	28	23	92	48	4	69	115	53	45	62	7°	100	156	1,3
GK45DO	45	6	58	32	27	102	52	4	77	128	60	50,8	68	7°	127	208	1,8
GK50DO	50	6	62	35	30	112	59	4	88	144	66	55,9	75	6°	156	250	2,5
GK60DO	60	6	70	44	38	135	72,5	4	100	167,5	80	66,8	90	6°	245	390	3,9
GK70DO	70	6	80	49	42	160	86	5	115	195	92	77,9	105	6°	315	510	6,6
GK80DO	80	6	95	55	47	180	98	5	141	231	105	89,4	120	6°	400	620	8,7