

Conveyor chains (ZE series)

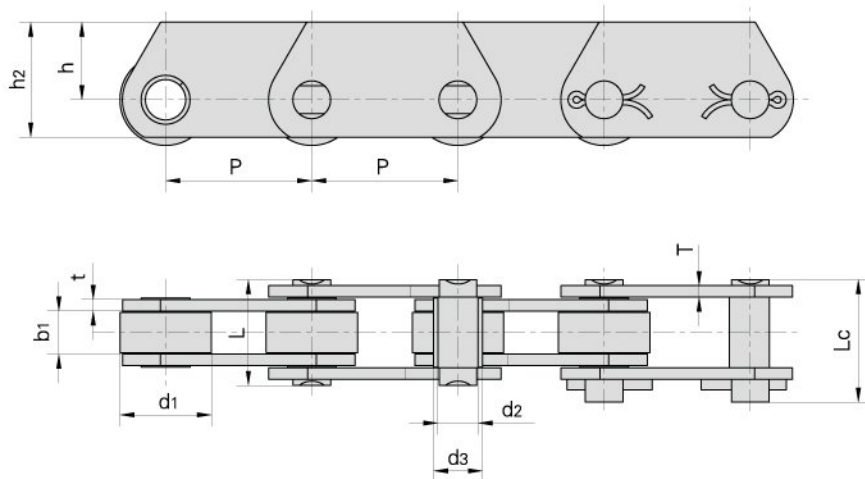

Chain No.	Pitch							Roller diameter	Pin diameter	Bush diameter
	P							d ₁ max	d ₂ max	d ₃ max
	mm							mm	mm	mm
ZE40	50.8	63.5	76.2	88.9	101.6	127.0	152.4	31.75	14.0	17.0
ZE100	76.2	88.9	101.6	127.0	152.4	177.8	203.2	47.50	19.0	23.0
ZE160	101.6	127.0	152.4	177.8	203.2	228.6	254.0	66.70	26.9	33.0
ZE300	152.4	177.8	203.2	254.0	304.8	-	-	88.90	32.0	38.0

Chain No.	Width between inner plates	Pin length		Plate depth		Plate thickness	Breaking load	
	b ₁ min	L max	L _c max	h ₂ max	h max	t/T max	Q min	*Q min
	mm	mm	mm	mm	mm	mm	kN/LB	kN/LB
ZE40	15.0	37.0	40.5	40.0	27.0	4.0	40.0/9091	60.0/13636
ZE100	19.0	45.0	50.5	50.0	30.0	5.0/4.0	100.0/22725	160.0/36360
ZE160	26.0	58.0	63.5	70.0	45.0	7.0/5.0	160.0/36360	200.0/45454
ZE300	38.0	84.0	94.0	90.0	60.0	10.0/8.0	300.0/68175	380.0/86362

*Q Higher breaking load with hardened plates