

Short pitch stainless steel conveyor chain with attachments

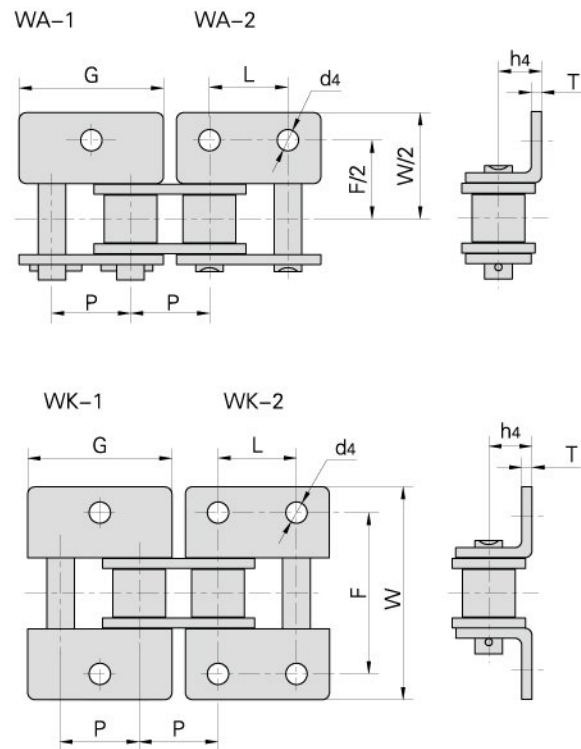

Chain No.	P	G	L	F	W	T	h4	d4
	mm	mm	mm	mm	mm	mm	mm	mm
40SS	12.700	23.00	12.700	25.4	35.60	1.50	7.90	3.4
50SS	15.875	28.80	15.875	31.8	46.80	2.03	10.30	5.5
60SS	19.050	34.65	19.050	38.1	56.40	2.42	11.90	5.5
80SS	25.400	45.90	25.400	50.8	73.20	3.25	15.90	6.8
100SS	31.750	57.65	31.750	63.5	89.80	4.00	19.80	9.2
08BSS	12.700	24.00	12.700	25.4	36.40	1.60	8.90	4.3
10BSS	15.875	29.58	15.875	31.8	44.60	1.70	10.31	5.3
12BSS	19.050	34.05	19.050	38.1	52.40	1.85	13.46	6.4
16BSS	25.400	46.40	25.400	50.8	72.60	3.10	15.88	6.4
20BSS	31.750	58.10	31.750	63.0	100.50	3.50	19.80	9.0