

SP series high strength short pitch roller chains

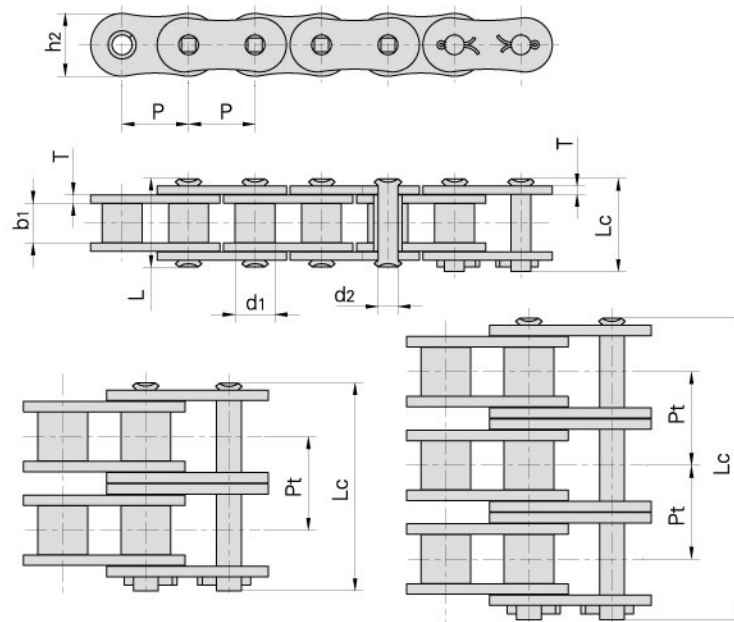

Chain No.	Pitch	Roller diameter	Width between inner plates	Pin diameter	Pin length		Inner plate depth	Plate thickness	Transverse pitch	Ultimate tensile strength	Average tensile strength	Weight per meter
	P	d1 max	b1 min	d2 max	L max	Lc max	h2 max	T	Pt	Q min	Q0	q
	mm	mm	mm	mm	mm	mm	mm	mm	mm	kN/LB	kN	kg/m
80SP-1	25.40	15.88	15.75	7.94	32.7	36.5	24.1	3.2	-	77.5/17434	85.3	2.86
100SP-1	31.75	19.05	18.95	9.54	40.4	44.7	30.1	4.0	-	115.5/25982	127.0	4.21
120SP-1	38.10	22.23	25.22	11.11	50.3	54.3	36.2	4.8	-	165.0/37118	186.0	6.36
140SP-1	44.45	25.40	25.22	12.71	54.4	59.0	42.2	5.6	-	222.7/50098	245.0	8.04
160SP-1	50.80	28.58	31.55	14.29	64.8	69.6	48.2	6.4	-	285.5/64215	314.0	10.80
200SP-1	63.50	39.68	37.85	19.85	80.3	87.2	60.3	8.0	-	445.5/100208	490.0	18.00
80SP-2	25.40	15.88	15.75	7.94	62.7	65.8	24.1	3.2	29.29	155.0/34868	170.6	5.68
100SP-2	31.75	19.05	18.95	9.54	76.4	80.5	30.1	4.0	35.76	231.0/51965	255.0	8.34
120SP-2	38.10	22.23	25.22	11.11	95.8	99.7	36.2	4.8	45.44	339.0/76260	373.0	12.63
140SP-2	44.45	25.40	25.22	12.71	103.3	107.9	42.2	5.6	48.87	445.5/100218	490.0	15.92
160SP-2	50.80	28.58	31.55	14.29	123.3	128.1	48.2	6.4	58.55	571.0/128430	628.0	21.43
200SP-2	63.50	39.68	37.85	19.85	151.9	158.8	60.3	8.0	71.55	892.0/200621	981.0	35.00
80SP-3	25.40	15.88	15.75	7.94	91.7	95.1	24.1	3.2	29.29	232.5/52302	255.9	8.18
100SP-3	31.75	19.05	18.95	9.54	112.2	116.3	30.1	4.0	35.76	347.3/78128	382.0	12.47
120SP-3	38.10	22.23	25.22	11.11	141.4	145.2	36.2	4.8	45.44	508.0/114278	559.0	18.90
140SP-3	44.45	25.40	25.22	12.71	152.2	156.8	42.2	5.6	48.87	668.0/150271	735.0	23.84
160SP-3	50.80	28.58	31.55	14.29	181.8	186.6	48.2	6.4	58.55	855.5/192441	941.0	32.10
200SP-3	63.50	39.68	37.85	19.85	223.5	230.4	60.3	8.0	71.55	1336.4/300633	1470.0	52.50

SP series high strength heavy duty short pitch roller chains

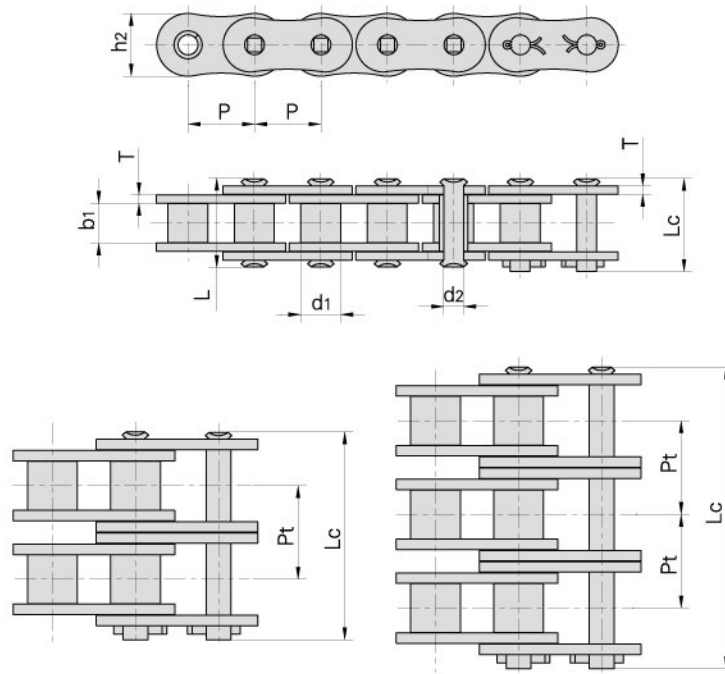

Chain No.	Pitch	Roller diameter	Width between inner plates	Pin diameter	Pin length		Inner plate depth	Plate thickness	Transverse pitch	Ultimate tensile strength	Average tensile strength	Weight per meter
	P	d1 max	b1 min	d2 max	L max	Lc max	h2 max	T	Pt	Q min	Q0	q
	mm	mm	mm	mm	mm	mm	mm	mm	mm	kN/LB	kN	kg/m
80HSP-1	25.40	15.88	15.75	7.94	36.2	38.9	24.1	4.0	-	89.2/20066	98.1	3.36
100HSP-1	31.75	19.05	18.95	9.54	43.6	46.9	30.1	4.8	-	131.8/29649	145.0	4.90
120HSP-1	38.10	22.23	25.22	11.11	53.5	57.5	36.2	5.6	-	176.0/39592	196.0	7.12
140HSP-1	44.45	25.40	25.22	12.71	57.6	62.2	42.2	6.4	-	231.9/52149	255.0	8.88
160HSP-1	50.80	28.58	31.55	14.29	68.2	73.0	48.2	7.2	-	294.5/66260	324.0	11.72
200HSP-1	63.50	39.68	37.85	19.85	86.6	93.5	60.3	9.5	-	543.6/122295	598.0	19.80
80HSP-2	25.40	15.88	15.75	7.94	68.8	72.0	24.1	4.0	32.59	178.4/40132	196.2	6.65
100HSP-2	31.75	19.05	18.95	9.54	82.7	86.0	30.1	4.8	39.09	263.6/59299	290.0	9.71
120HSP-2	38.10	22.23	25.22	11.11	102.4	106.4	36.2	5.6	48.87	356.4/80175	392.0	14.12
140HSP-2	44.45	25.40	25.22	12.71	109.8	114.4	42.2	6.4	52.20	463.6/104300	510.0	17.38
160HSP-2	50.80	28.58	31.55	14.29	130.1	134.9	48.2	7.2	61.90	588.0/132275	647.0	23.00
200HSP-2	63.50	39.68	37.85	19.85	164.9	171.8	60.3	9.5	78.31	1091.0/245429	1200.0	38.50
80HSP-3	25.40	15.88	15.75	7.94	101.4	104.6	24.1	4.0	32.59	267.6/60200	294.3	9.95
100HSP-3	31.75	19.05	18.95	9.54	121.8	125.1	30.1	4.8	39.09	395.4/88948	435.0	14.53
120HSP-3	38.10	22.23	25.22	11.11	151.2	155.2	36.2	5.6	48.87	534.5/120250	588.0	21.12
140HSP-3	44.45	25.40	25.22	12.71	162.0	166.6	42.2	6.4	52.20	695.5/156448	765.0	25.88
160HSP-3	50.80	28.58	31.55	14.29	192.0	196.8	48.2	7.2	61.90	882.7/198576	971.0	34.22
200HSP-3	63.50	39.68	37.85	19.85	243.2	250.1	60.3	9.5	78.31	1627.3/366073	1790.0	57.29

SP series high strength short pitch roller chains

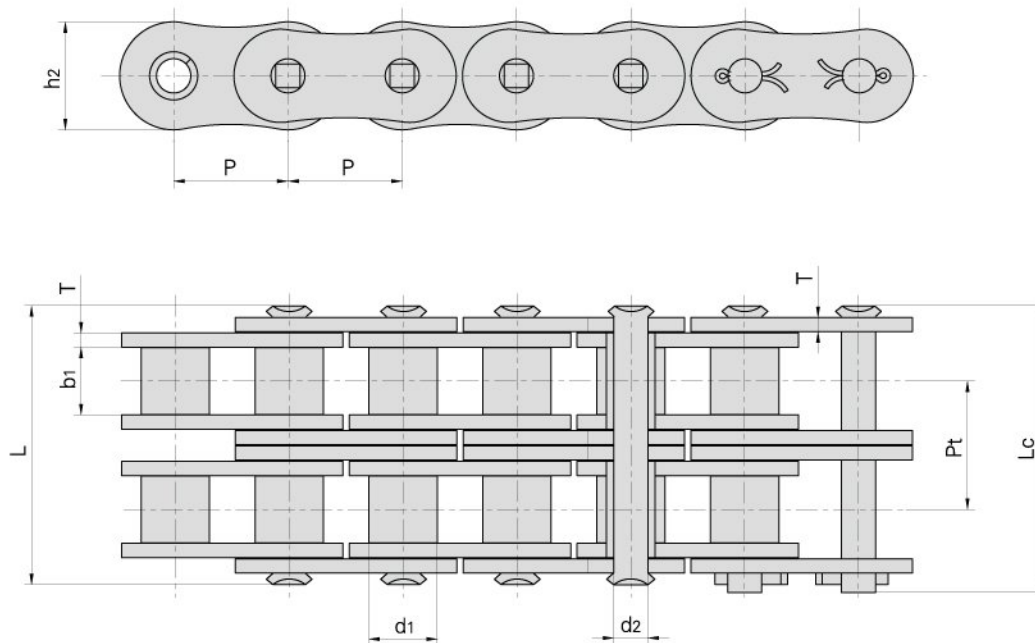

Chain No.	Pitch	Roller diameter	Width between inner plates	Pin diameter	Pin length		Inner plate depth	Plate thickness	Transverse pitch	Ultimate tensile strength	Average tensile strength	Weight per meter
	P mm	d1 max mm	b1 min mm	d2 max mm	L max mm	Lc max mm	h2 max mm	T mm	Pt mm	Q min kN/LB	Q0 kN	q kg/m
80SPE-2	25.40	15.88	15.75	7.94	62.7	65.8	24.1	3.2	29.29	155.0/34868	170.6	5.68
100SPE-2	31.75	19.05	18.95	9.54	76.4	80.5	30.1	4.0	35.76	231.0/51965	255.0	8.34
120SPE-2	38.10	22.23	25.22	11.11	95.8	99.7	36.2	4.8	45.44	339.0/76260	373.0	12.63
140SPE-2	44.45	25.40	25.22	12.71	103.3	107.9	42.2	5.6	48.87	445.5/100218	490.0	15.92
160SPE-2	50.80	28.58	31.55	14.29	123.3	128.1	48.2	6.4	58.55	571.0/128430	628.0	21.43
200SPE-2	63.50	39.68	37.85	19.85	151.9	158.8	60.3	8.0	71.55	892.0/200621	981.0	35.00
80HSPE-2	25.40	15.88	15.75	7.94	68.8	72.0	24.1	4.0	32.59	178.4/40132	196.2	6.65
100HSPE-2	31.75	19.05	18.95	9.54	82.7	86.0	30.1	4.8	39.09	263.6/59299	290.0	9.71
120HSPE-2	38.10	22.23	25.22	11.11	102.4	106.4	36.2	5.6	48.87	356.4/80175	392.0	14.12
140HSPE-2	44.45	25.40	25.22	12.71	109.8	114.4	42.2	6.4	52.20	463.6/104300	510.0	17.38
160HSPE-2	50.80	28.58	31.55	14.29	130.1	134.9	48.2	7.2	61.90	588.0/132275	647.0	23.00
200HSPE-2	63.50	39.68	37.85	19.85	164.9	171.8	60.3	9.5	78.31	1091.0/245429	1200.0	38.50

Note: central plates are press fit assembly.