

S type steel agricultural chains

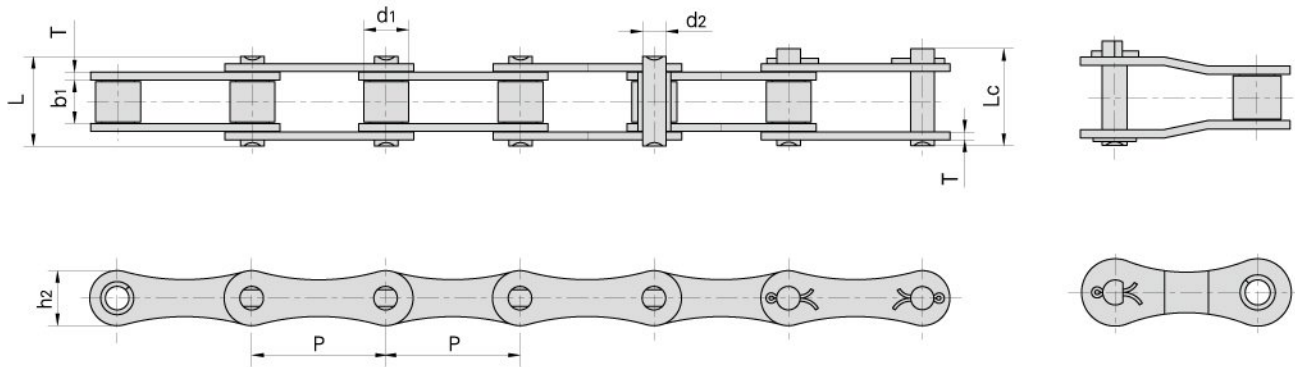

Chain No.	Pitch	Roller diameter	Width between inner plates	Pin diameter	Pin length		Inner plate depth	Plate thickness	Ultimate tensile strength	Average tensile strength	Weight per meter
	P	d1 max	b1 min	d2 max	L max	Lc max	h2 max	t/T max	Q min	Q0	q
	mm	mm	mm	mm	mm	mm	mm	mm	kN/LB	kN	kg/m
S32	29.21	11.43	15.88	4.45	26.7	28.8	13.2	1.8	8.0/1818	21.6	0.86
S32V	29.21	11.43	15.88	5.08	27.3	29.7	13.5	2.1	25.0/5680	27.0	0.96
S42	34.93	14.27	19.05	7.00	34.3	37.0	19.8	2.8	27.0/6136	50.8	1.60
S45	41.40	15.24	22.23	5.72	37.7	40.4	17.3	2.8	18.0/4091	36.1	1.66
S51	38.10	15.24	16.00	5.72	30.9	33.8	17.3	2.8	28.0/6364	30.8	1.48
S52L	38.10	15.24	16.40	5.72	30.9	33.8	16.5	2.5	29.2/6636	32.2	1.36
S52LV	38.10	15.88	17.80	6.94	33.8	37.0	16.7	3.0	30.0/6818	32.5	1.58
S52	38.10	15.24	22.23	5.72	37.7	40.4	17.3	2.8	18.0/4091	36.1	1.68
55V	41.40	17.90	22.23	8.22	39.3	42.4	20.0	3.0	42.0/9546	45.0	2.22
55VF1	41.40	17.90	22.23	8.22	39.3	42.4	21.4	3.0	45.0/10227	73.1	2.32
S55	41.40	17.78	22.23	5.72	37.7	40.4	17.3	2.8	18.0/4091	36.1	1.80
S55R	41.40	17.78	22.23	8.90	41.0	44.0	22.4	3.5	45.0/10227	73.1	2.49
S55RH	41.40	17.78	22.23	8.90	43.2	46.4	22.4	4.0	65.0/14772	84.5	2.74
S55RHF1	41.40	25.00	22.23	8.90	43.2	46.4	22.4	4.0	65.0/14772	84.5	2.74
S62	41.91	19.05	26.20	5.72	40.3	43.0	17.3	2.5	26.7/6067	36.1	1.87
S62F5	41.91	19.05	26.20	5.72	40.3	43.0	16.7	2.5	26.7/6067	36.1	2.07
S77	58.34	18.26	22.23	8.90	43.2	46.4	26.2	4.0	45.0/10227	73.1	2.66
S88	66.27	22.86	28.58	8.90	49.8	53.0	26.2	4.0	45.0/10227	73.1	3.25
CA642	41.40	15.88	19.00	8.28	36.1	39.1	21.2	3.0	50.0/11363	55.0	1.98
CA650	50.80	25.00	18.90	9.53	40.4	44.7	25.0	4.0	90.0/20454	95.5	3.49
CA650F2	50.80	20.00	18.90	9.53	40.4	44.7	25.0	4.0	90.0/20454	95.5	2.98
S42F2	34.93	14.27	19.05	7.00	34.3	37.0	19.8	2.5/3.0	27.0/6136	50.8	1.82
S52F10	38.10	14.00	22.00	6.92	36.5	39.1	18.2	2.5	23.5/5283	28.2	1.60
S62F10	41.91	19.05	25.40	5.72	39.4	42.2	17.3	2.5	26.7/6067	36.1	2.04
S62F8	41.91	19.05	27.90	10.00	44.9	49.3	25.0	3.0	45.0/10227	60.0	2.96
CA650F4	50.80	19.05	19.05	5.93	40.4	44.7	25.0	4.0	90/20454	95.5	2.85
CA620F4	42.01	19.05	27.90	10.19	44.9	46.5	25.0	3.0	45/10277	60.0	2.95

S type steel agricultural chains

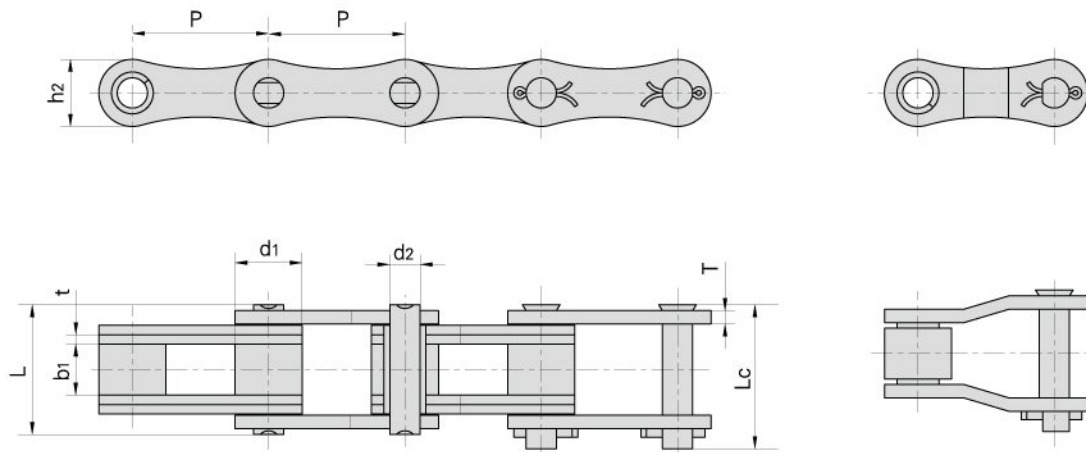

Chain No.	Pitch	Roller diameter	Width between inner plates	Pin diameter	Pin length		Inner plate depth	Plate thickness	Ultimate tensile strength	Average tensile strength	Weight per meter
	P	d1 max	b1 min	d2 max	L max	Lc max	h2 max	t/T max	Q min	Q0	q
	mm	mm	mm	mm	mm	mm	mm	mm	kN/LB	kN/LB	kg/m
55VF1H2	41.4	17.9	22.23	8.22	45.3	48.4	21.4	3.0	60.0/11858	65.0	2.92
CA650F1	50.8	25.0	19.0	11.28	49.2	53.7	25.0	3.5/5.0	138.0/27273	140.0	4.36