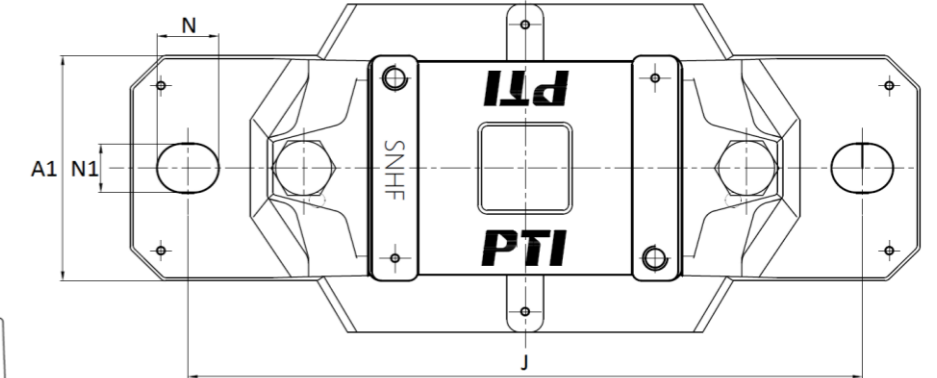
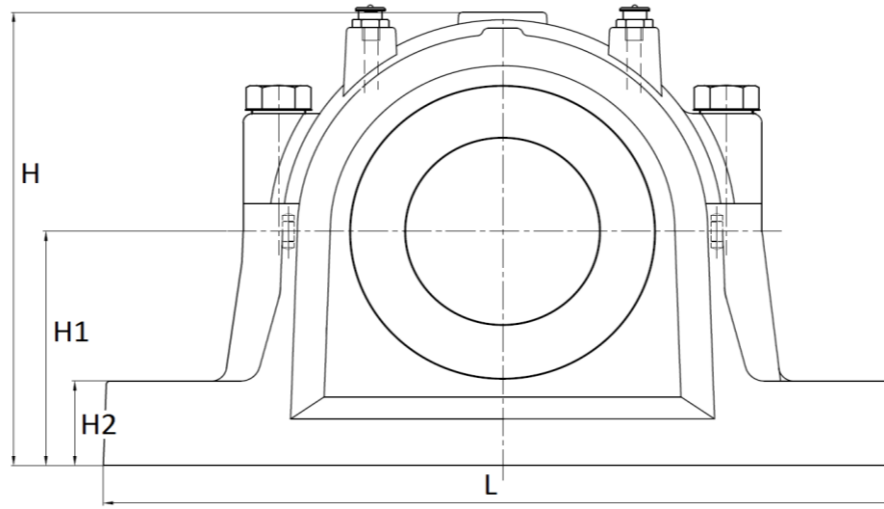
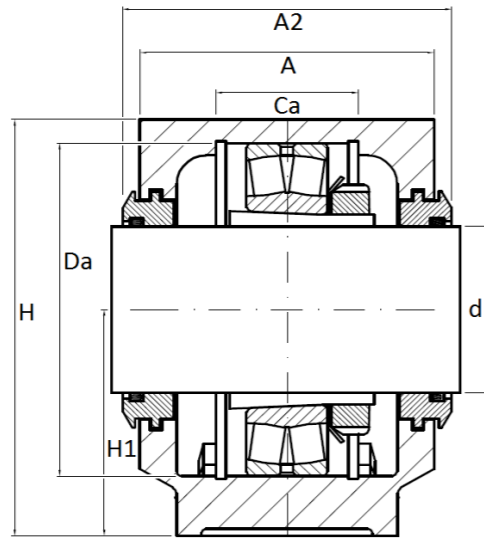
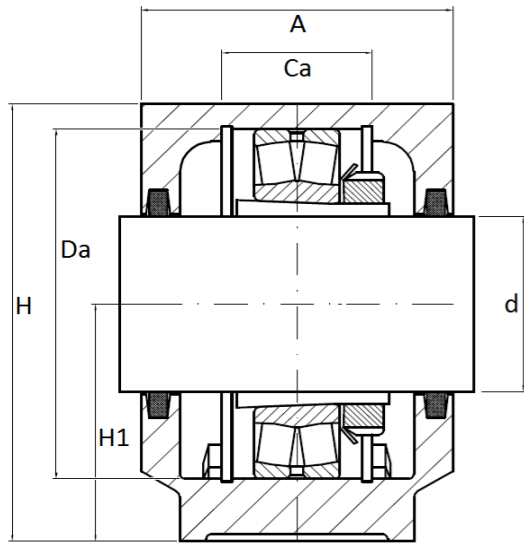
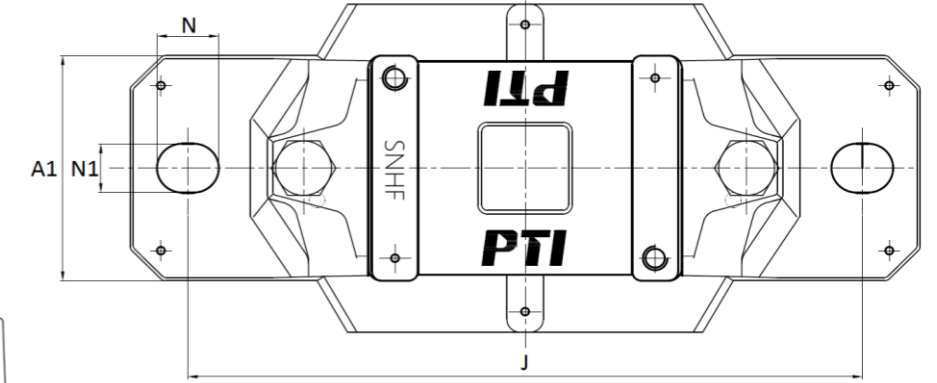
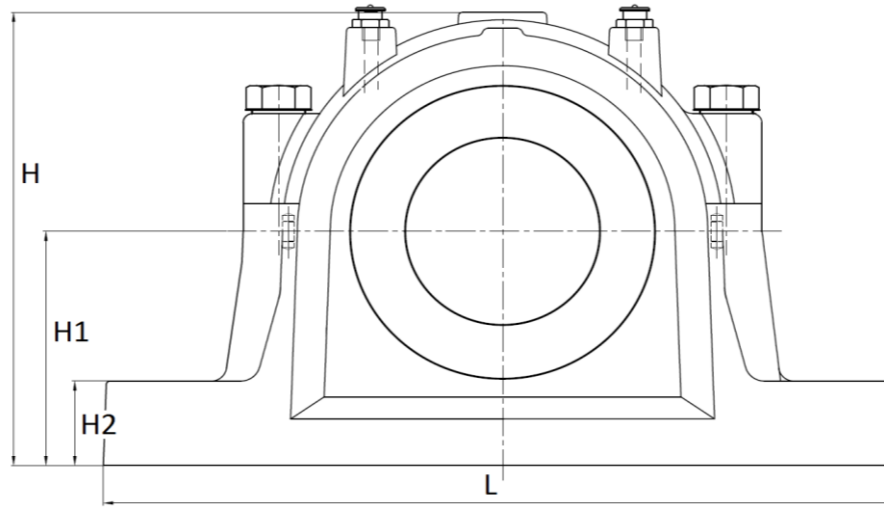
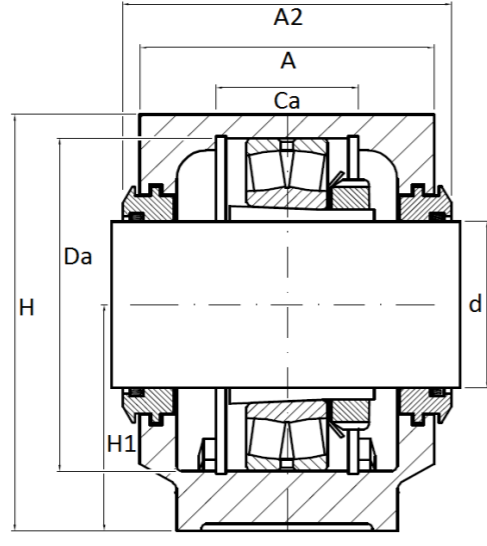
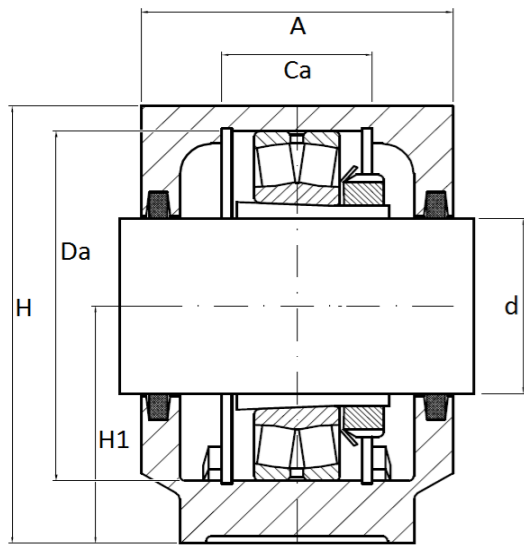
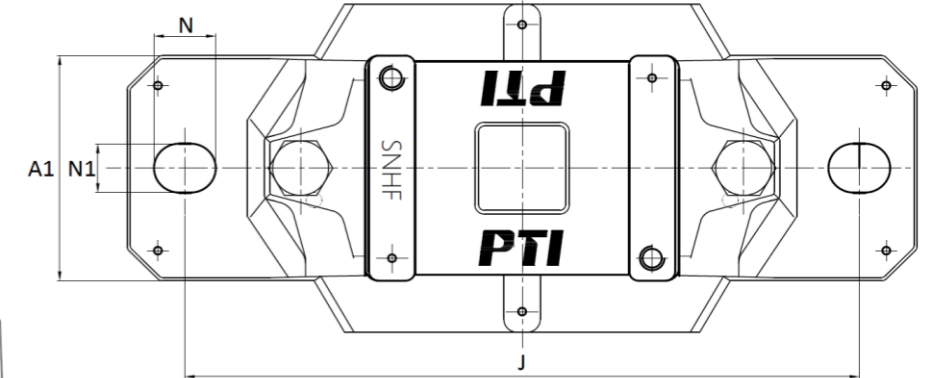
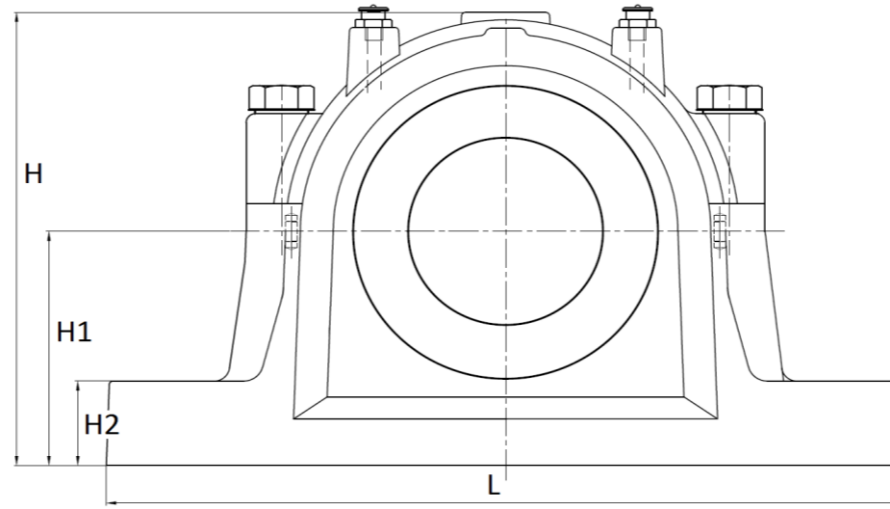
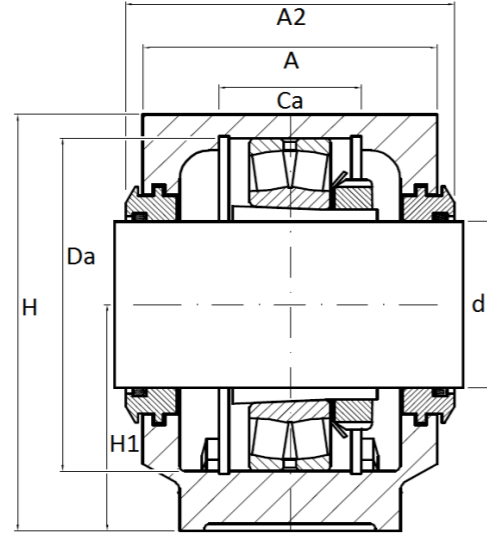
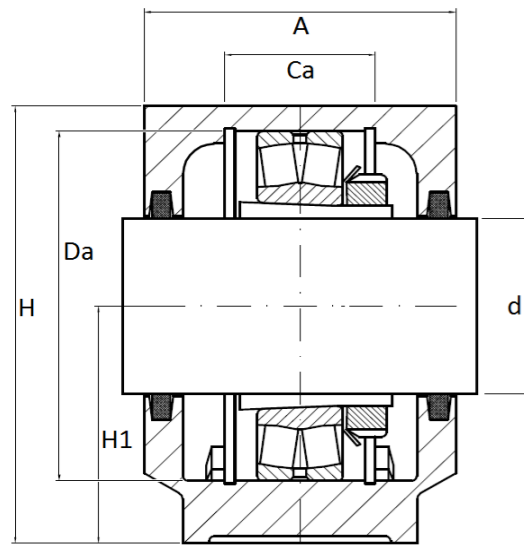

Felt seal, Rubber seal and V-ring seal
Labyrinth seal

Part No.	Shaft size	Dimensions (mm)											Mounting Bolt	Bearings	Adapter Sleeves	Fixing Rings	Housing No.	Double Lip Seals	V-ring Seals	Felt Seals	Labyrinth Seals	End cover	Weight (kg)	
		A	A1	A2	Ca	Da	H	H1	H2	J	L	N												N1
SNHF 605	20	77	52	89	32	62	89	50	22	150	185	20	15	M12	1305 K	H 305	2 x FR 62-7.5	SNHF 506-605	TSN605G	TSN605A	TSN605C	TS05-605	ASNH506-605	2
															2305 K	H 2305	2 x FR 62-4							
SNHF 606	25	82	52	94	34	72	93	50	22	150	185	20	15	M12	1306 K	H 306	2 x FR 72-7.5	SNHF 507-606	TSN606G	TSN606A	TSN606C	TS06-606	ASNH507-606	2,2
															2306 K	H 2306	2 x FR 72-3.5							
SNHF 607	30	85	60	97	39	80	107	60	25	170	205	20	15	M12	1307 K	H 307	2 x FR 80-9	SNHF 508-607	TSN607G	TSN607A	TSN607C	TS07-607	ASNH508-607	2,9
															2307 K	H 2307	2 x FR 80-4							
SNHF 608	35	90	60	102	41	90	113	60	25	170	205	20	15	M12	1308 K	H 308	2 x FR 90-9	SNHF 510-608	TSN608G	TSN608A	TSN608C	TS08-608	ASNH510-608	3,2
															2308 K	H 2308	2 x FR 90-4							
															21308 K	H 308	2 x FR 90-9							
															22308 K	H 2308	2 x FR 90-4							
SNHF 609	40	95	70	107	44	100	127	70	28	210	255	24	18	M16	1309 K	H 209	2 x FR 100-9.5	SNHF 511-609	TSN609G	TSN609A	TSN609C	TS09-609	ASNH511-609	4,4
															2309 K	H 2309	2 x FR 100-4							
															21309 K	H 309	2 x FR 100-9.5							
															22309 K	H 2309	2 x FR 100-4							
SNHF 610	45	105	70	117	48	110	133	70	30	210	255	24	18	M16	1310 K	H 310	2 x FR 110-10.5	SNHF 512-610	TSN610G	TSN610A	TSN610C	TS10-610	ASNH 513-610	5,1
															2310 K	H 2310	2 x FR 110-4							
															21310 K	H 310	2 x FR 110-10.5							
															22310 K	H 2310	2 x FR 110-4							

Felt seal, Rubber seal and V-ring seal
Labyrinth seal

Part No.	Shaft size	Dimensions (mm)											Mounting Bolt	Bearings	Adapter Sleeves	Fixing Rings	Housing No.	Double Lip Seals	V-ring Seals	Felt Seals	Labyrinth Seals	End cover	Weight (kg)	
		A	A1	A2	Ca	Da	H	H1	H2	J	L	N												N1
SNHF 611	50	110	80	122	51	120	148	80	30	230	275	24	18	M16	1311 K	H 311	2 x FR 120-11	SNHF 513-611	TSN611G	TSN611A	TSN611C	TS11-611	ASNH 513-611	5,1
															2311 K	H 2311	2 x FR 120-4							
															21311 K	H 311	2 x FR 120-11							
															22311 K	H 2311	2 x FR 120-4							
SNHF 612	55	115	80	127	56	130	154	80	30	230	280	24	18	M16	1312 K	H 312	2 x FR 130-12.5	SNHF 515-612	TSN612G	TSN612A	TSN612C	TS12-612	ASNH 515-612	7
															2312 K	H 2312	2 x FR 130-5							
															21312 K	H 312	2 x FR 130-12.5							
															22312 K	H 2312	2 x FR 130-5							
SNHF 613	60	120	90	138	58	140	175	95	32	260	315	28	22	M20	1313 K	H 313	2 x FR 140-12.5	SNHF 516-613	TSN613G	TSN613A	TSN613C	TS13-613	ASNH516-613	9,5
															2313 K	H 2313	2 x FR 140-5							
															21313 K	H 313	2 x FR 140-12.5							
															22313 K	H 2313	2 x FR 140-5							
SNHF 615	65	140	100	158	65	160	193	100	35	290	345	28	22	M20	1315 K	H 315	2 x FR 160-14	SNHF 518-615	TSN615G	TSN615A	TSN615C	TS15-615	ASNH518-615	12,5
															2315 K	H 2315	2 x FR 160-5							
															21315 K	H 315	2 x FR 160-14							
															22315 K	H 2315	2 x FR 160-5							
SNHF 616	70	145	100	163	68	170	210	112	35	290	345	28	22	M20	1316 K	H 316	2 x FR 170-14.5	SNHF 519-616	TSN616G	TSN616A	TSN 616 C	TS 16-616	ASNH 519-616	13,7
															2316 K	H 2316	2 x FR 170-5							
															21316 K	H 316	2 x FR 170-14.5							
															22316 K	H 2316	2 x FR 170-5							

Felt seal, Rubber seal and V-ring seal
Labyrinth seal

Part No.	Shaft size	Dimensions (mm)											Mounting Bolt	Bearings	Adapter Sleeves	Fixing Rings	Housing No.	Double Lip Seals	V-ring Seals	Felt Seals	Labyrinth Seals	End cover	Weight (kg)	
		A	A1	A2	Ca	Da	H	H1	H2	J	L	N												N1
SNHF 617	75	160	110	178	70	180	215	112	40	320	380	32	26	M24	1317 K	H 317	2 x FR 180-14.5	SNHF 520-617	TSN617G	TSN617A	TSN617C	TS17-617	ASNH520-617	17,6
															2317 K	H 2317	2 x FR 180-5							
															21317 K	H 317	2 x FR 180-14.5							
															22317 K	H 2317	2 x FR 180-5							
SNHF 618	85	175	120	191	80	200	239	125	45	350	410	32	26	M24	1319 K	H 319	2 x FR 200-17.5	SNHF 522-619	TSN619G	TSN619A	TSN619C	TS19-619	ASNH522-619	22
															2319 K	H 2319	2 x FR 200-6.5							
															21319 K	H 319	2 x FR 200-17.5							
															22319 K	H 2319	2 x FR 200-6.5							
SNHF 620	90	185	120	199	86	215	271	140	45	350	410	32	26	M24	1320 K	H 320	2 x FR 215-19.5	SNHF 524-620	TSN620G	TSN620A	TSN620C	TS20-620	ASHN524-620	26,2
															2320 K	H 2320	2 x FR 215-6.5							
															21320 K	H 320	2 x FR 215-19.5							
															22320 K	H 2320	2 x FR 215-6.5							