

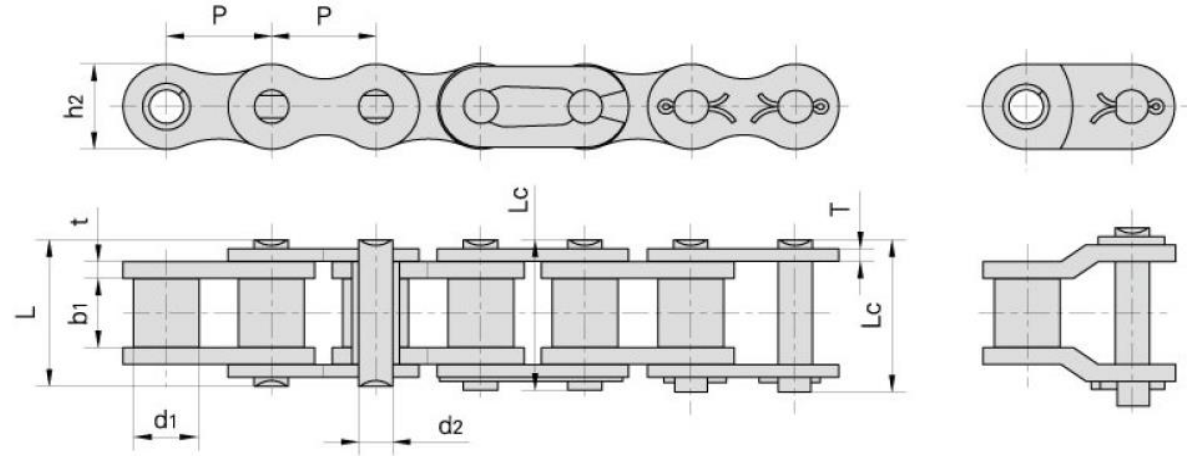

Short pitch precesion roller chains (B series)

Simplex roller chains



DIN/ISO Chain No.	Pitch (mm)	Roller Diameter (mm)	Width between inner plates (mm)	Pin Diameter (mm)	Pin Length (mm)		Inner plate depth	Plate thickness (mm)	Ultimate tensile strength Q _{min}	Avarage tensile strength Q ₀	Weight pr. meter q
	P	d _{1max}	b _{1min}	d _{2max}	L _{max}	L _{cmax}	h _{2max}	t/T _{max}	kN/LB	kN	kg/m
04B-1	6,000	4,00	2,80	1,85	6,80	7,8	5,00	0,60	3,0/682	3,2	0,11
05B-1	8,000	5,00	3,00	2,31	8,20	8,9	7,10	0,80	5,0/1136	5,9	0,20
*06B-1	9,525	6,35	5,72	3,28	13,15	14,1	8,20	1,30	9,0/2045	10,4	0,41
08B-1	12,700	8,51	7,75	4,45	16,70	18,2	11,80	1,60	18,0/4091	19,4	0,69
10B-1	15,875	10,16	9,65	5,08	19,50	20,9	14,70	1,70	22,4/5091	27,5	0,93
12B-1	19,050	12,07	11,68	5,72	22,50	24,2	16,00	1,85	29,0/6591	32,2	1,15
16B-1	25,400	15,88	17,02	8,28	36,10	37,4	21,00	4,15/3,1	60,0/13636	72,8	2,71
20B-1	31,750	19,05	19,56	10,19	41,30	45,0	26,40	4,5/3,5	95,0/21591	106,7	3,70
24B-1	38,100	25,4	25,40	14,63	53,40	57,8	33,20	6,0/4,8	160,0/36364	178,0	7,10
28B-1	44,450	27,94	30,99	15,90	65,10	69,5	36,70	7,5/6,0	200,0/45455	222,0	8,50
32B-1	50,800	29,21	30,99	17,81	66,00	71,0	42,00	7,0/6,0	250,0/56818	277,5	10,25
40B-1	63,500	39,37	38,10	22,89	82,20	89,2	52,96	8,5/8,0	355,0/80682	394,0	16,35
48B-1	76,200	48,26	45,72	29,24	99,10	107,0	63,80	12,0/10,0	560,0/127272	621,6	25,00
56B-1	88,900	53,98	53,34	34,32	114,60	123,0	77,80	13,5/12,0	850,0/193180	940,0	35,78
64B-1	101,600	63,5	60,96	39,40	130,00	138,5	90,17	15,0/13,0	112,0/254544	1240,0	46,00
72B-1	114,300	72,39	68,58	44,48	147,40	156,4	103,60	17,0/15,0	1400,0/318180	1550,0	60,80

*Straight side plates

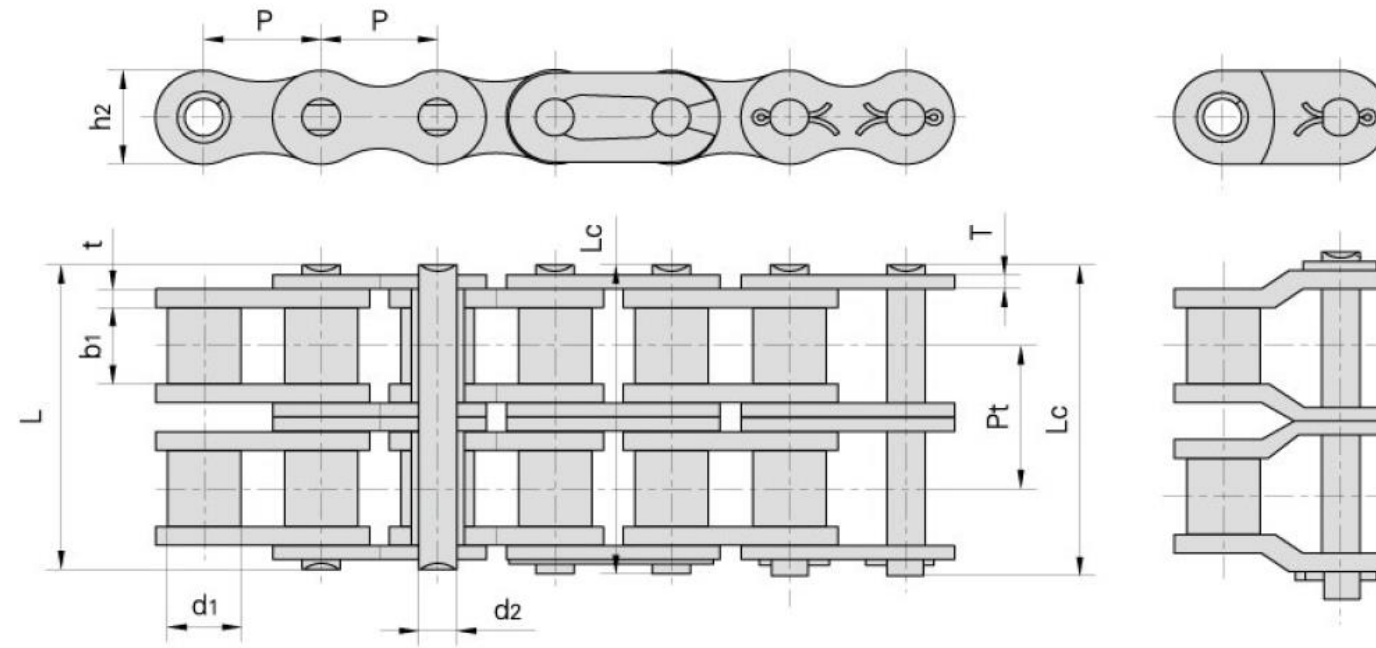

DIN/ISO Chain No.	Pitch (mm)	Roller Diameter (mm)	Width between inner plates (mm)	Pin Diameter (mm)	Pin Length (mm)	Inner plate depth (mm)	Plate thickness (mm)	Transverse pitch (mm)	Ultimate tensile strength Q _{min} (kN/LB)	Average tensile strength Q ₀ (kN)	Weight pr. meter q (kg/m)	
	P	d _{1max}	b _{1min}	d _{2max}	L _{max}	L _{Cmax}	h _{2max}	t/T _{max}	Pt			
05B-2	8,000	5,00	3,00	2,31	13,9	14,5	7,10	0,80	5,64	7,8/1773	10,2	0,33
*06B-2	9,525	6,35	5,72	3,28	23,4	24,4	8,20	1,30	10,24	16,9/3841	18,7	0,77
08B-2	12,700	8,51	7,75	4,45	31,0	32,2	11,80	1,60	13,92	32,0/7273	38,7	1,34
10B-2	15,875	10,16	9,65	5,08	36,1	37,5	14,70	1,70	16,59	44,5/10114	56,2	1,84
12B-2	19,050	12,07	11,68	5,72	42,0	43,6	16,00	1,85	19,46	57,8/13136	66,1	2,31
16B-2	25,400	15,88	17,02	8,28	68,0	69,3	21,00	4,15/3,1	31,88	106,0/24091	133,0	5,42
20B-2	31,750	19,05	19,56	10,19	77,8	81,5	26,40	4,5/3,5	36,45	170,0/38636	211,2	7,20
24B-2	38,100	25,40	25,40	14,63	101,7	106,2	33,20	6,0/4,8	48,36	280,0/63636	319,2	13,40
28B-2	44,450	27,94	30,99	15,90	124,6	129,1	36,70	7,5/6,0	59,56	360,0/81818	406,8	16,60
32B-2	50,800	29,21	30,99	17,81	124,6	129,6	42,00	7,0/6,0	58,55	450,0/102273	508,5	21,00
40B-2	63,500	39,37	38,10	22,89	154,5	151,5	52,96	8,5/8,0	72,29	630,0/143182	711,9	32,00
48B-2	76,200	48,26	45,72	29,24	190,4	198,2	63,80	12,0/10,0	91,21	1000,0/227272	1130,0	50,00
56B-2	88,900	63,98	53,34	34,32	221,2	229,6	77,80	13,5/12,0	106,60	1600,0/363635	1760,0	71,48
64B-2	101,600	63,50	60,96	39,40	249,9	258,4	90,17	15,0/13,0	119,89	2000,0/454544	2200,0	91,00
72B-2	114,300	72,39	68,58	44,48	283,7	293	103,60	17,0/15,0	136,27	2500,0/568180	2750,0	120,40

*Straight side plates

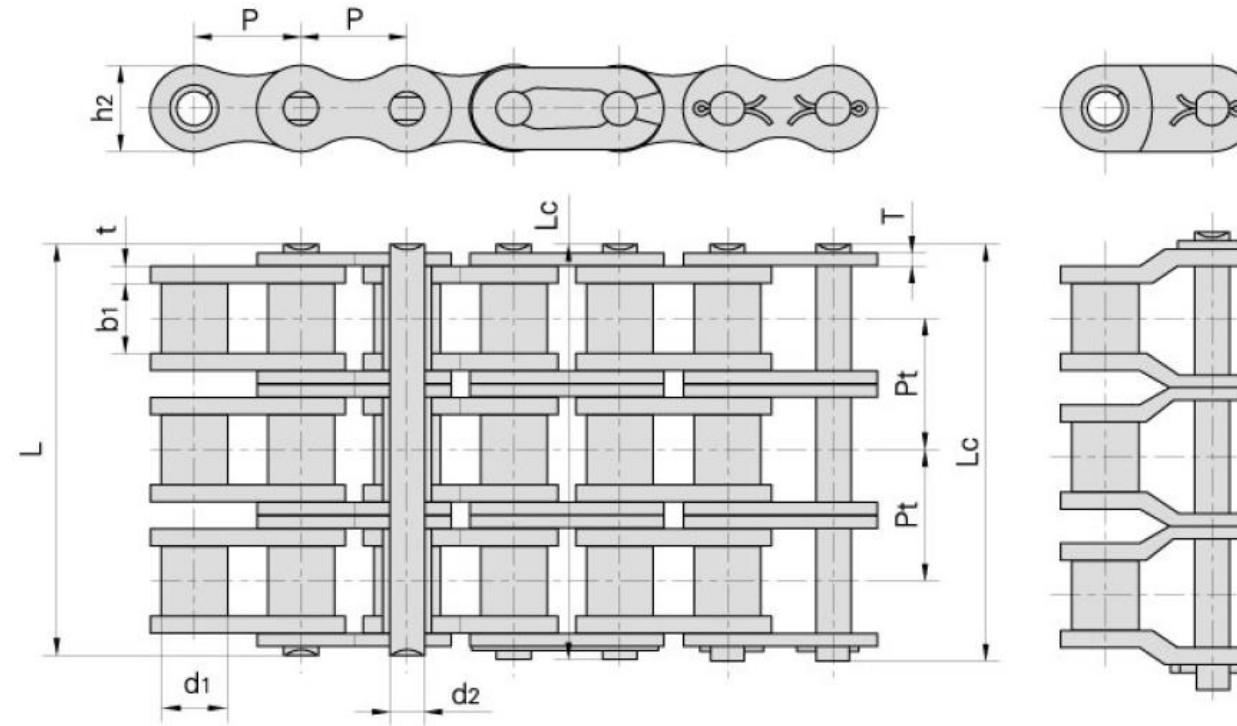

DIN/ISO Chain No.	Pitch (mm)	Roller Diameter (mm)	Width between inner plates (mm)	Pin Diameter (mm)	Pin Length (mm)	Inner plate depth (mm)	Plate thickness (mm)	Transverse pitch (mm)	Ultimate tensile strength Q _{min} (kN/LB)	Average tensile strength Q ₀ (kN)	Weight pr. meter q (kg/m)	
	P	d1 _{max}	b1 _{min}	d2 _{max}	L _{max}	L _{cmax}	h2 _{max}	t/T _{max}	Pt			
05B-3	8,000	5,00	3,00	2,31	19,5	20,2	7,10	0,80	5,64	11.1/2523	13,8	0,48
*06B-2	9,525	6,35	5,72	3,28	33,5	34,6	8,20	1,30	10,24	24,9/5659	30,1	1,16
08B-3	12,700	8,51	7,75	4,45	45,1	46,1	11,80	1,60	13,92	47,5/10795	57,8	2,03
10B-3	15,875	10,16	9,65	5,08	52,7	54,1	14,70	1,70	16,59	66,7/15159	84,5	2,77
12B-3	19,050	12,07	11,68	5,72	61,5	63,1	16,00	1,85	19,46	86,7/19705	101,8	3,46
16B-3	25,400	15,88	17,02	8,28	99,8	101,2	21,00	4,15/3,1	31,88	160,0/36364	203,7	8,13
20B-3	31,750	19,05	19,56	10,19	114,2	117,9	26,40	4,5/3,5	36,45	250,0/56818	290,0	10,82
24B-3	38,100	25,40	25,40	14,63	150,1	154,6	33,20	6,0/4,8	48,36	425,0/96591	493,0	20,10
28B-3	44,450	27,94	30,99	15,90	184,2	188,7	36,70	7,5/6,0	59,56	530,0/120454	609,5	24,92
32B-3	50,800	29,21	30,99	17,81	183,2	188,2	42,00	7,0/6,0	58,55	670,0/152273	770,5	31,56
40B-3	63,500	39,37	38,10	22,89	226,8	233,8	52,96	8,5/8,0	72,29	950,0/215909	1092,5	48,10
48B-3	73,200	48,26	45,72	29,24	281,6	289,4	63,80	12,0/10,0	91,21	1500,0/340909	1710,0	75,00
56B-3	88,900	53,98	53,34	34,32	327,8	336,2	77,80	13,5/12,0	106,60	2240,0/545450	2240,0	107,18
64B-3	101,600	63,50	60,69	39,40	369,8	378,3	90,17	15,0/13,0	119,89	3000,0/681820	3300,0	136,00
72B-3	114,300	72,39	68,58	44,48	420,0	429,0	103,60	17,0/15,0	136,27	3750,0/852270	4125,0	180,00

*Straight side plates