

Universal movement conveyor chains

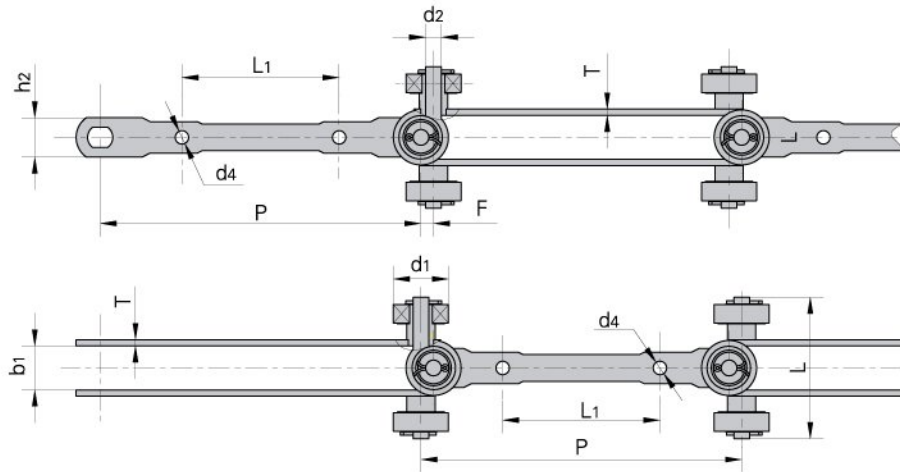

Chain No.	Pitch	Roller diameter	Width between inner plates	Pin diameter	Pin length	plate dimension		Attachment dimension			Ultimate tensile strength
	P	d1 max	b1 min	d2 max	L max	h2 max	T max	L1	d4	F	Q min
	mm	mm	mm	mm	mm	mm	mm	mm	mm	mm	kN/LB
P210	204.0	35.0	27.5	10.0	90.0	25.0	4.0	100.0	8.5	8.0	50.0/11364
SJ406S-50	203.2	35.0	27.5	10.0	90.0	25.0	4.0	100.0	8.5	11.0	50.0/11364

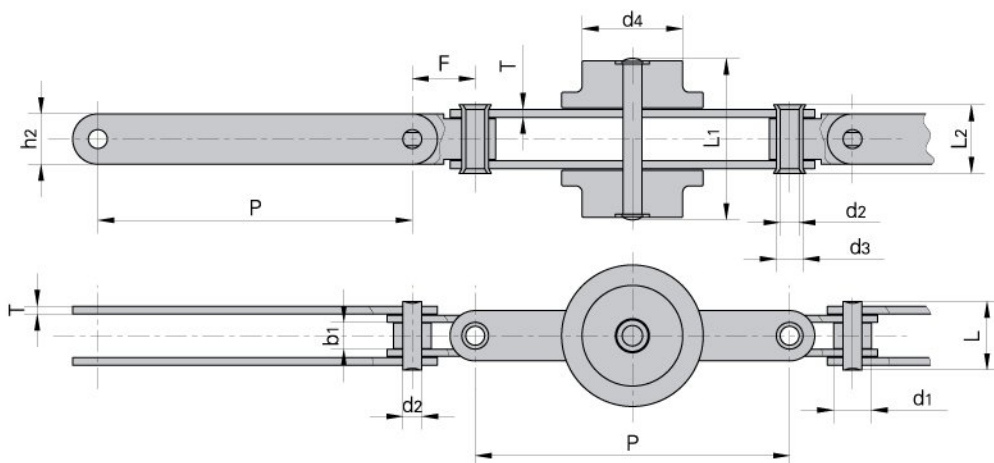

Chain No.	Pitch	Roller diameter		Width between inner plates	Pin diameter		Pin length			plate dimension		Attachment dimension	Ultimate tensile strength
	P	d1 max	d4 max	b1 min	d2	d3	L max	L1 max	L2 max	h2 max	T max	F	Q min
	mm	mm	mm	mm	mm	mm	mm	mm	mm	mm	mm	mm	kN/LB
P100F11	100.0	12.0	32.0	8.6	6.0	8.5	22.0	53.0	22.0	16.0	2.5	20.0	20.0/4545

Universal movement conveyor chains

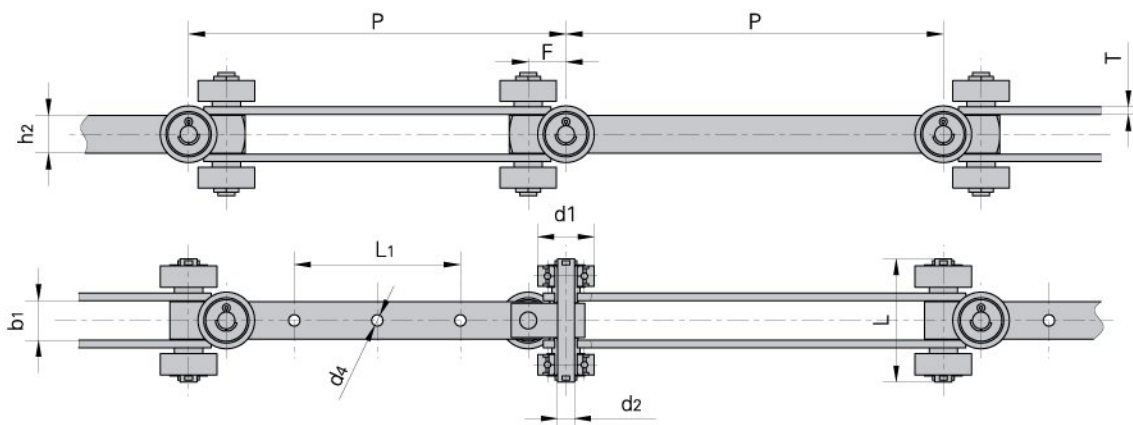

Chain No.	Pitch	Roller diameter	Width between inner plates	Pin diameter	Pin length	plate dimension		Attachment dimension			Ultimate tensile strength
	P	d1 max	b1 min	d2 max	L max	h2 max	T max	L1	d4	F	Q min
	mm	mm	mm	mm	mm	mm	mm	mm	mm	mm	kN/LB
SJ400-40	200.0	30.0	20.0	9.0	65.0	20.0	3.0	88.0	6.44	20.0	15.0/3374
SJ400-60	200.0	35.0	21.0	10.0	64.5	20.0	4.0	88.0	6.50	20.0	60.0/13497
SJ400-100	200.0	40.0	26.0	14.0	75.0	30.0	4.0	88.0	10.00	25.0	100.0/22495
SJ405S-60	203.2	47.0	30.0	14.0	95.0	30.0	4.0	76.2	8.40	16.5	50.0/11247

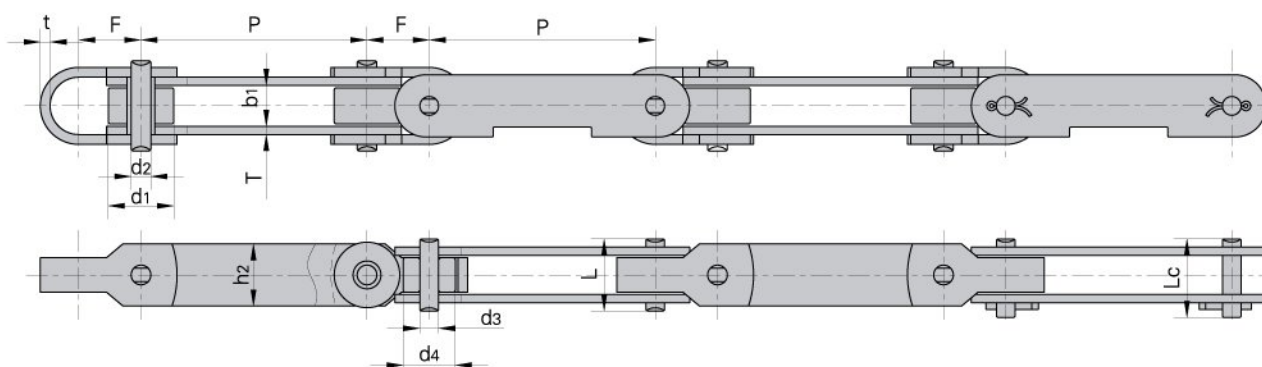

Chain No.	Pitch	Roller diameter		Width between inner plates	Pin diameter		Pin length		plate dimension		Attachment dimension		Ultimate tensile strength
	P	d1 max	d4 max	b1 min	d2	d3	L max	Lc max	h2 max	T max	F	t	Q min
	mm	mm	mm	mm	mm	mm	mm	mm	mm	mm	mm	mm	kN/LB
P69F2	69.0	20.0	15.9	8.6	6.0	5.72	22.0	24.0	19.0	2.5	19.0	3.0	20.0/4545