

## Hollow pin conveyor chains (FVC series)

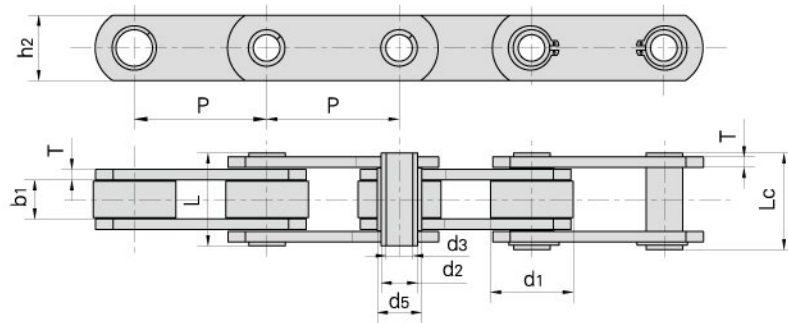

without rollers

with S small rollers type

with P large rollers type

with F flanged rollers type

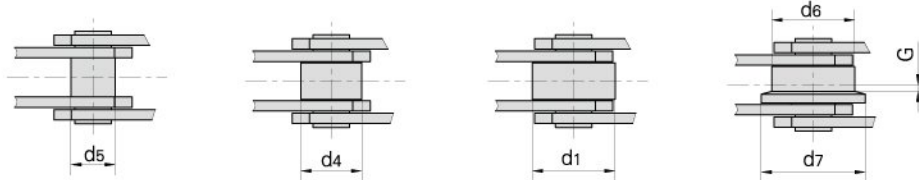

DIN Chain No.	Pitch							Roller dimension				
	P							d1 max	d4 max	d6 max	d7 max	G
	mm	mm	mm	mm	mm	mm	mm	mm	mm	mm	mm	
FVC63	63.0	80.0	100.0	125.0	160.0	–	–	40.0	26.0	50.0	63.0	5.0
FVC90	63.0	80.0	100.0	125.0	160.0	200.0	250.0	48.0	30.0	63.0	78.0	6.5
FVC112	100.0	125.0	160.0	200.0	250.0	–	–	55.0	32.0	72.0	90.0	7.5
FVC140	100.0	125.0	160.0	200.0	250.0	–	–	60.0	36.0	80.0	100.0	9.0
FVC180	125.0	160.0	200.0	250.0	315.0	–	–	70.0	42.0	100.0	125.0	13.0
FVC250	160.0	200.0	250.0	315.0	400.0	–	–	80.0	50.0	125.0	155.0	15.0
FVC315	160.0	200.0	250.0	315.0	400.0	–	–	90.0	60.0	140.0	175.0	18.0

DIN Chain No.	Width between inner plates	Pin diameter			Bush diameter	Pin length		Plate thickness	Plate depth	Ultimate tensile strength
	b1 min mm	d2 max mm	d3 min mm	d5 max mm	L max mm	Lc max mm	T max mm	h2 max mm	Q min kN/LB	
FVC63	22.0	12.0	8.0	18.0	45.0	50.5	4.0	30.0	46.0/10454	
FVC90	25.0	14.0	10.0	20.0	53.0	56.5	5.0	35.0	73.0/16590	
FVC112	30.0	16.0	11.0	22.0	62.0	63.0	6.0	40.0	90.0/20454	
FVC140	35.0	18.0	12.0	26.0	67.0	68.5	6.0	45.0	110.0/25000	
FVC180	45.0	20.0	14.0	30.0	86.0	88.0	8.0	50.0	145.0/32954	
FVC250	55.0	26.0	18.0	36.0	97.0	103.5	8.0	60.0	215.0/48863	
FVC315	65.0	30.0	20.0	42.0	117.0	121.5	10.0	70.0	295.0/67044	